

GY6/G-MAX RECHARGEABLE HIGH ROTATIONAL SPEED ALTERNATOR ASSY INSTALLING PHOTOS

- 1. Engine
- 2. Stator Coil
- 3. Flywheel
- 4. Fan
- 5. M6*P1.0*L12
(Screw Outer Diameter MAX10.5)
- 6. M4*P0.7*16
- 7. M5*P0.8*14
- 8. M6*P1.0*L16
(Spring Washer*1 & Plate Washer*1)
- 9. Sensor Attachment
- 10. Stator Coil Attachment

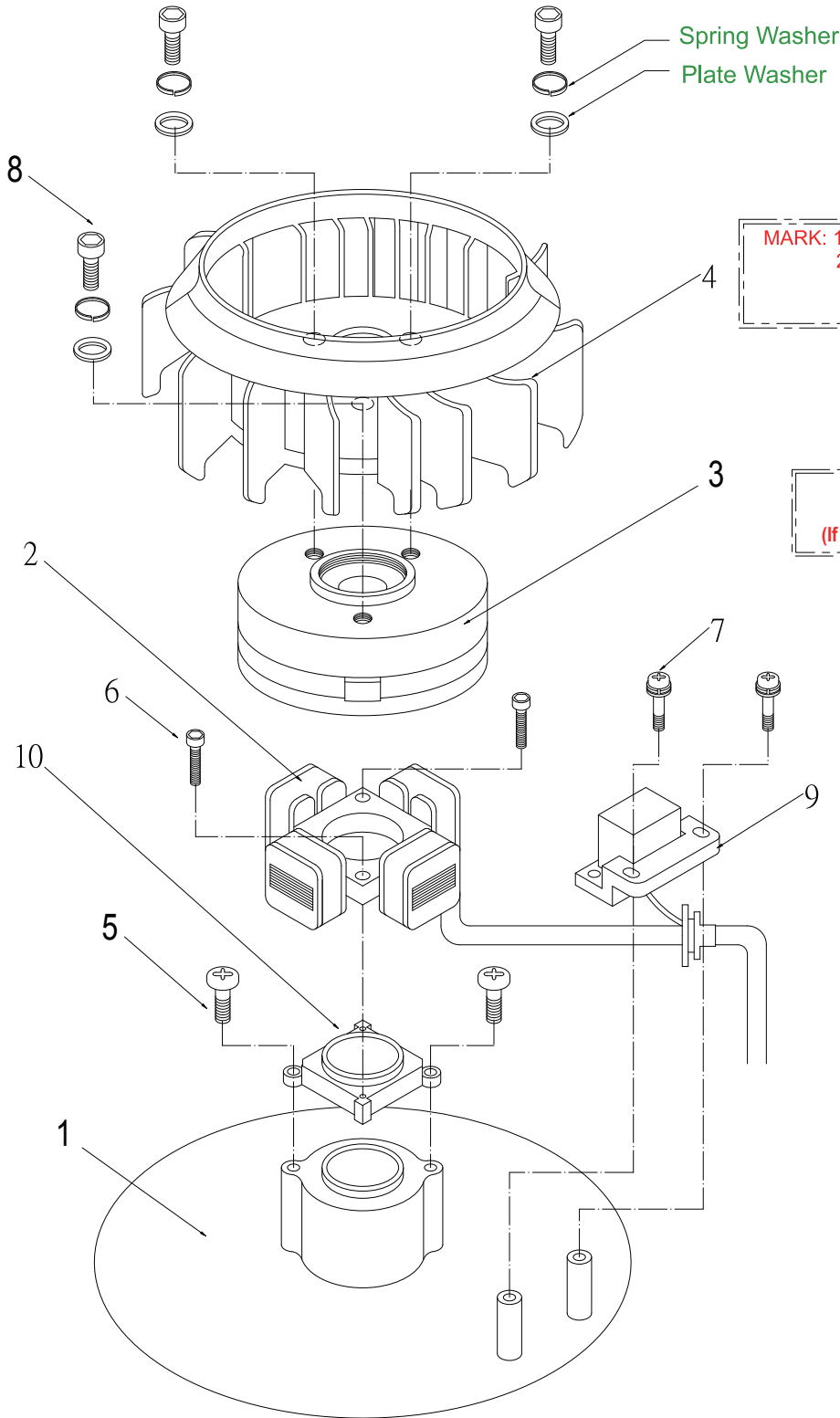

MARK: 1. All screws have to be locked very well.
2. Fan screw have to be locked well with Plate Washer and Spring Washer for fear that Fan gets loose and the screws are too long and touch Stator Coil.

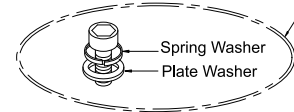

MARK :3. Have to take apart the Pink Line of Resistor.
(If you don't have RESISTOR, please ignore this step.)

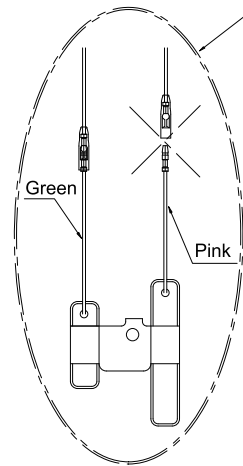

The installing interspace between Sensor and Flywheel plug is 1mm.

